

Models 9203P-S, 9253P-C, 9500P-S and 9553P-C

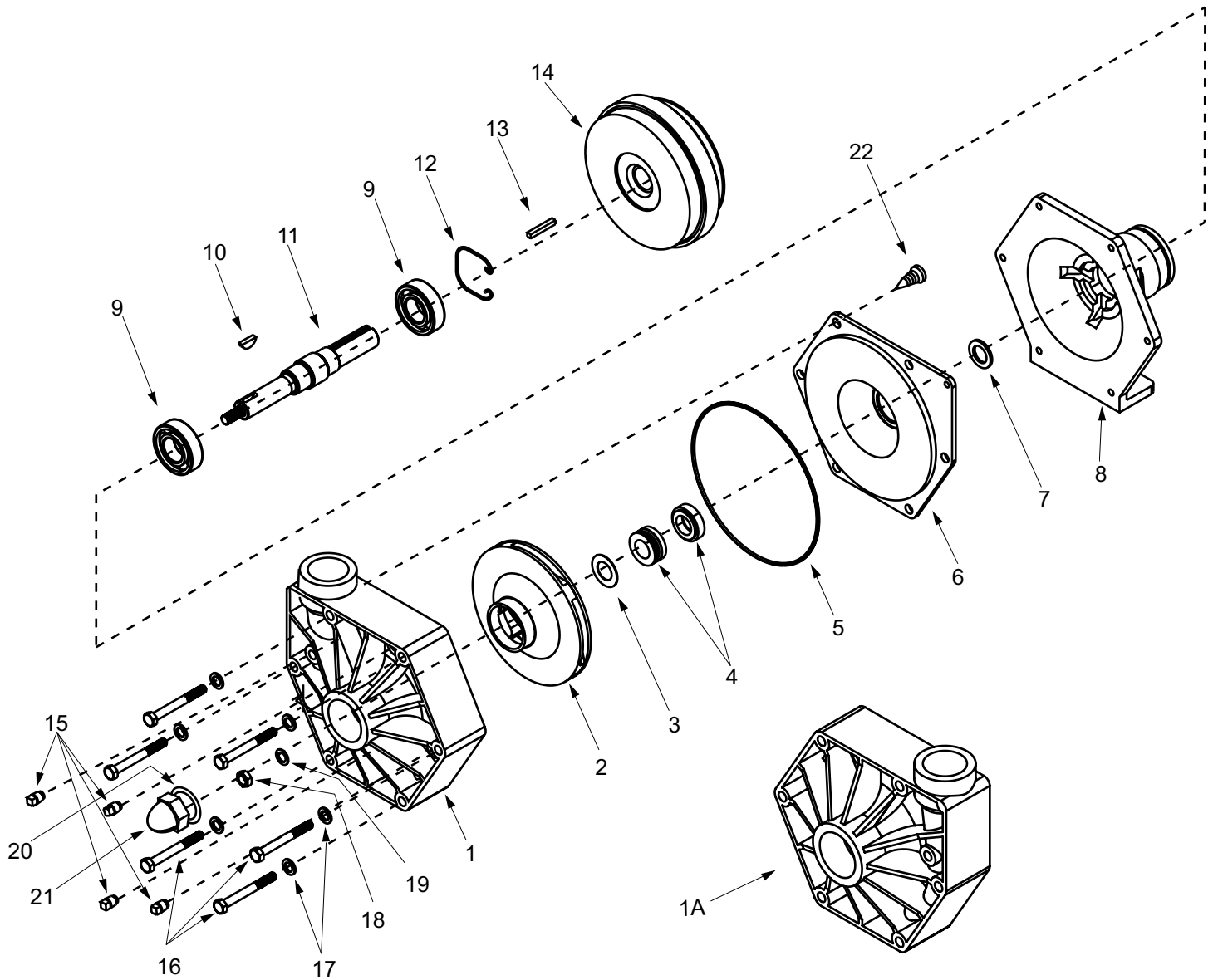

SEAL KIT FOR ALL MODELS

No. 3430-0333 consists of:

- (1) Ref. 3 Gasket
- (1) Ref. 4 Mechanical Seal
- (1) Ref. 5 O-ring
- (1) Ref. 19 Washer
- (1) Ref. 20 Gasket

Note: When ordering parts, give quantity, part number, description and complete model number. Reference numbers are used ONLY to identify parts in the drawing and NOT to be used as order numbers.

No.	Qty. Req'd.	Part No.	Description
1	1	0700-9000P	Pump Casing (9203P-S, 9253P-C)
1A	1	0701-9500P	Pump Casing (9500P-S, 9553P-C)
2	1	0403-9000P	Impeller (Polypropylene) 9203P-S, 9253P-C
2A	1	0402-9000P	Impeller (Polypropylene) 9500P-S, 9553P-C
3	1	1700-0101	Gasket
4	1	2120-0011	Mechanical Seal
5	1	1721-0083	O-ring
6	1	0750-9000P	Back Cover (9203P-S, 9253P-C)
6A	1	0700-9500P	Back Cover (9500P, 9553P-C)
7	1	1410-0083	Slinger Ring
8	1	0702-9200C	Flange
9	2	2008-0001	Bearing
10	1	1610-0042	Woodruff Key (Stainless Steel)

Ref. No.	Qty. Req'd.	Part No.	Description
11	1	0507-9200	Shaft (316 Stainless Steel)
12	1	1820-0025	Retaining Ring
13	1	1610-0004	Key
14	1	2526-0011	Clutch (Models 9253P-C and 9553P-C only)
15	4	2406-0020	Plug
16	6	2210-0087	Hex head Bolt
17	6	2270-0041	Washer
18	1	2250-0051	Jam Nut
19	1	2270-0057	Washer
20	1	1700-0097	Gasket
21	1	2250-0052	Impeller Nut
22	1	2210-0088	Screw

9203P-S 9253P-C		GPM at HP		GPM at HP		GPM at HP		GPM at HP		GPM at HP		GPM at HP		GPM at HP			
	RPM	10 PSI		20 PSI		30 PSI		40 PSI		50 PSI		60 PSI		70 PSI		80 PSI	
	2400	63	1.5	49	1.4	29	1.1										
	3600	91	4.4	87	4.3	81	4.1	70	3.9	58	3.6	39	3.6				
4200	103	6.7	101	6.6	98	6.5	90	6.3	82	6.0	71	5.7	60	5.2	42	4.5	

9203P-S 9253P-C		LPM at HP		LPM at HP		LPM at HP		LPM at HP		LPM at HP		LPM at HP		LPM at HP			
	RPM	0.7 BAR		1.4 BAR		2.1 BAR		2.8 BAR		3.4 BAR		4.1 BAR		4.8 BAR		5.5 BAR	
	2400	238	1.5	185	1.4	110	1.1										
	3600	344	4.4	329	4.3	307	4.1	265	3.9	220	3.6	148	3.1				
4200	390	6.7	382	6.6	371	6.5	341	6.3	310	6.0	269	5.7	227	5.2	159	4.5	

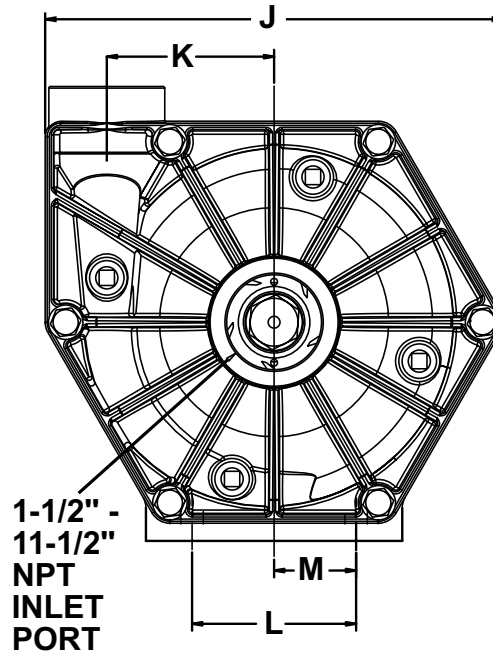
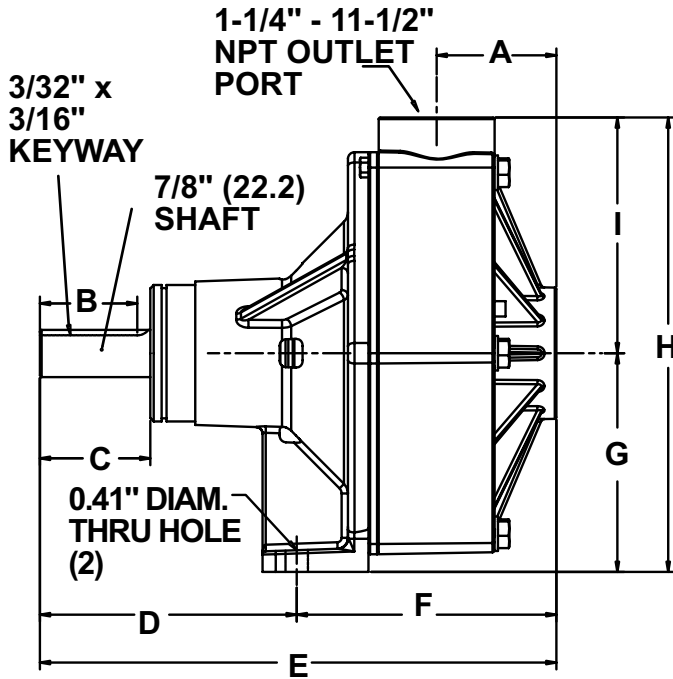

9203P

Dimensions		
Inches	mm	
A	2.19	55.6
B	1.78	45.2
C	2.02	51.3
D	4.7	119
E	9.45	240
F	4.75	121
G	4	102
H	8.31	211
I	4.31	109
J	8.38	213
K	3.06	77.7
L	3	76.2
M	1.5	38.1

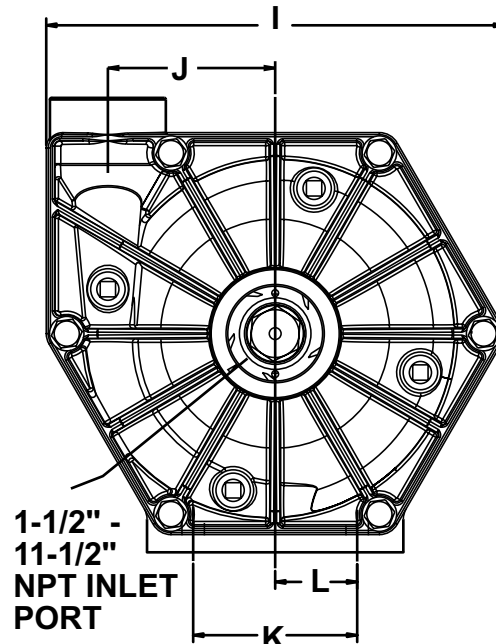
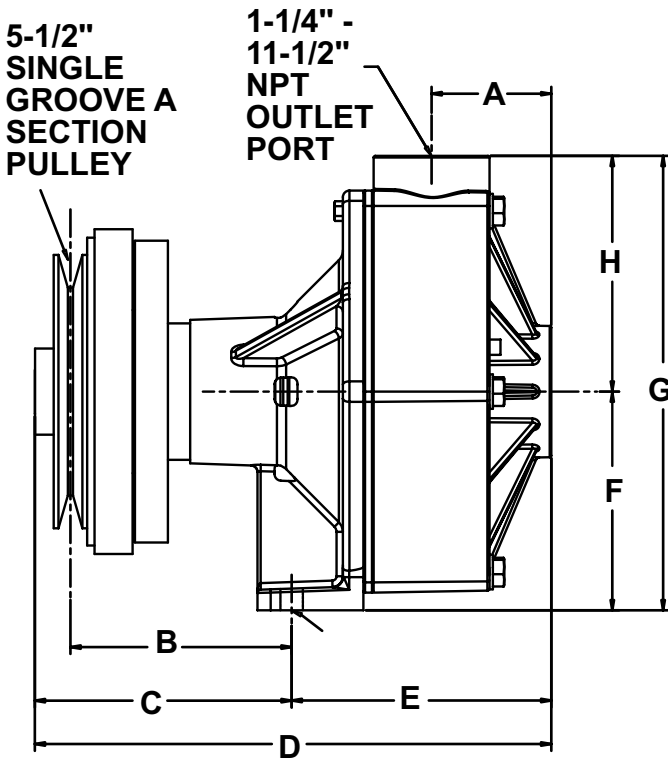

9253P-C

Dimensions		
Inches	mm	
A	2.19	55.6
B	4.05	103
C	4.7	119
D	9.45	240
E	4.75	121
F	4	102
G	8.31	211
H	4.31	109
I	8.38	213
J	3.06	77.7
K	3	76.2
L	1.5	38.1